

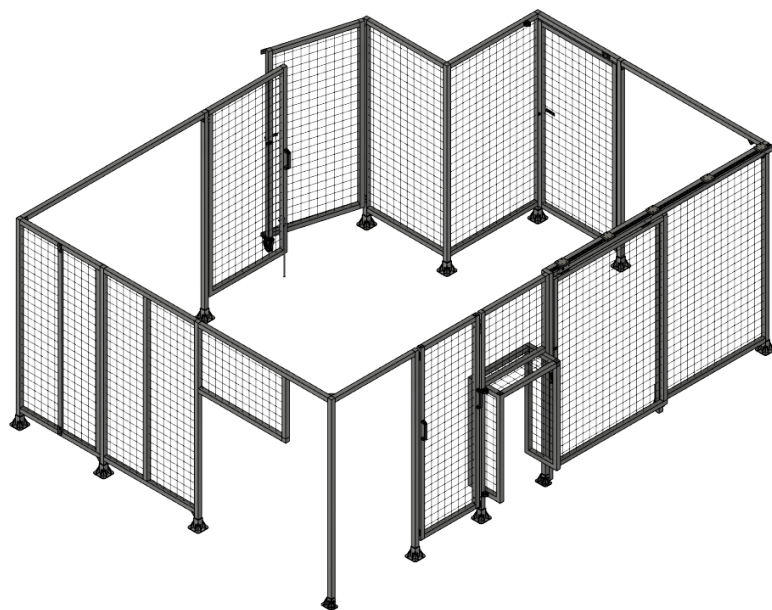

American Manufacturer - Modular Systems

*Save Time & Money*

## COMPANY OVERVIEW



### Benefits:

- Buy Factory Direct & Save
- Online Store
- Guarding Configurators
- Local Inventory
- Custom Engineered Solutions

### Features:

- Industry Standard Profile
- Speedlock - Hidden Profile Fastener
- Solution Focused Systems
- Standardized Hardware & Connectors
- Hardware Included with Accessories

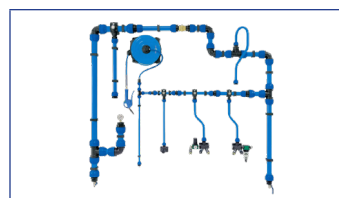
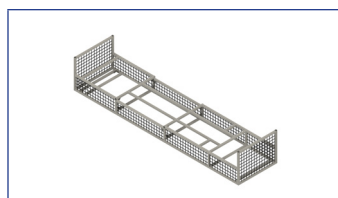
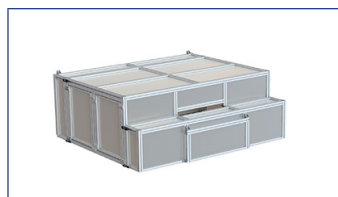
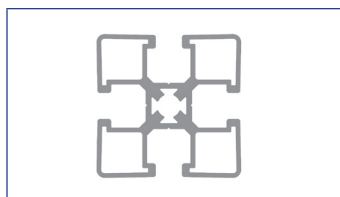

## Robotic & Equipment Guarding

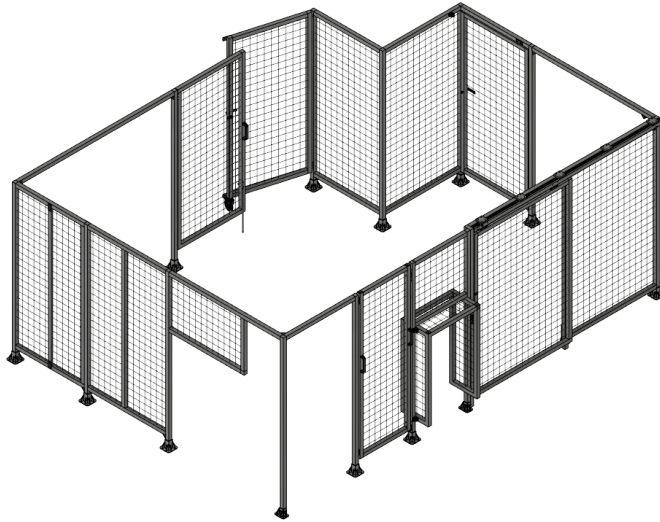

### Features

- Custom Guarding or Easy to Order Quick Guard Sections Available
- Experienced Sales Staff and Engineers Available to Assist you
- Additional Parts and Components Available
- Made from Our Industry Standard T-Slot Profile
- Profile Normally Stocked Locally
- Online Guarding Configurators
- Easy Order Guides
- Online Catalog

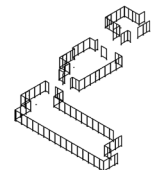
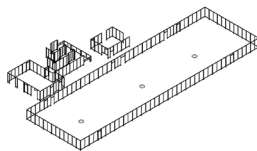
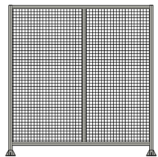

## Guarding Configurators

### Save Time

- Reduced Approval Process Time
- Part Numbers at Your Fingertips for Generating Your Customer Drawings
- Wall Section Bill of Materials for Final Customer
- Time to Quote, Order, and Ship - All Reduced
- Fast Turnaround on Build and Kit Orders

### Save Money

- Reduced Engineering Expense in Design and Approval Process
- Streamline Ordering Into Single Part Numbers
- Save Up to 20% When Ordering With Part Numbers Instead of Design to Order Assemblies

Enter your dimensions below to configure - \*\*Solid Works Library Available Upon Request\*\*

C2-2200-1000-1000-0150-TYMFA  
 Filtronic > Guarding

Part No.	C2-2200-1000-1000-0150-TYMFA
Guard Type	C2 - Single Leg on Right
Swamp	2500
Height	450
Width 1	200
Width 2	200
Connection on Non-Foot End	T - Tie Plates Top, Angle at Bottom
Revert Type	Y - Yellow
Panel Material	M - 1" x 1" Mesh
Foot Type	F - 4 Sided Foot
Assembled or Kit	A - Assembled (Factory Assembles)

Generate CAD    Generate PDF datasheet

3D Dimension

## Profile

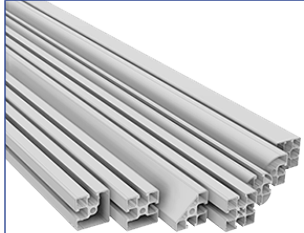

- Industry Standard Profile
- Speedlock - Hidden Profile Fastener
- Bulk Aluminum Available
- Standard Profile Made in the U.S.A.
- Local Stock
- Custom Colors/Powder Coating Available
- Order Online

## Conveyors



- Belt Conveyors
- Timing Belt Conveyors
- Gravity Conveyors
- Ball Transfer Conveyors
- Chain Conveyors

## Enclosures



- Sound Enclosures
- Laser Enclosures
- Dust-Proof Enclosures
- Clean Room Enclosures
- Small Tabletop Enclosures to Large Room Enclosures

## Work Stations



- Work Stations
- Work Benches
- Ergonomic Solutions

## Flow Racks



- Improve Productivity & Organization
- Available Options Such as Casters, Roller Tracks, Label Clips & More..

## Carts



- Utility Carts
- Battery Carts
- Kitting Carts
- Flatbed Carts
- Shelf Carts
- Ladder Carts
- Fitting Carts

## Racks

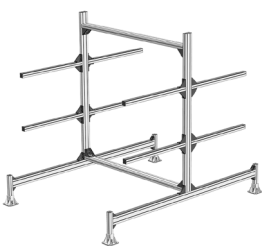

- Cantilever Racks
- Storage Racks
- Custom Shelves
- Reel Racks
- Dunnage Racks

## Doors & Hoods

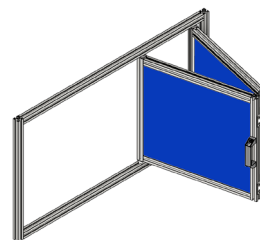

- Custom Doors & Hoods for Industrial & Factory Applications
- Linear Doors
- Folding Doors
- Swing Doors
- Custom Machine Hoods

## Modular Pipe



- Easy and Rapid Installation
- Reduced Pressure Drop
- Corrosion Resistance
- Reusable
- Fire-Resistant
- UV-Resistant
- NO Welding

## Inspection Drawers

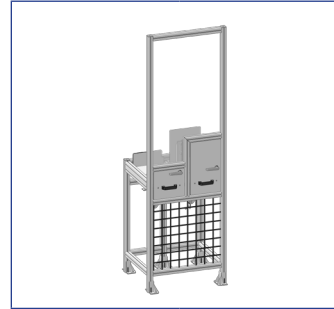

- Normally Used with Guarding and Robotic Systems
- Allows for Inspection of Parts Without Entering Cell
- High Load Capacity Telescoping Slide Rails Available
- Sliding Shelves Systems Also Available

## Stands & Fixtures

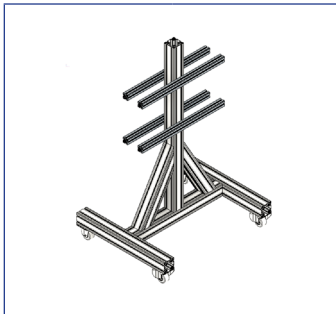

- Light Stands/Fixtures
- Test Stands/Fixtures
- Clamping Stands/Fixtures
- Holding Stands/Fixtures
- Measuring Stands/Fixtures
- Inspection Stands/Fixtures
- AV Stands/Fixtures

## Signs, Displays & Merchandising



- Signs
- Display Cases
- Wall Displays
- Stand Displays
- Podiums
- Trade Show Structures

## Other Linear Motion Systems

### UHMW Slide Rail

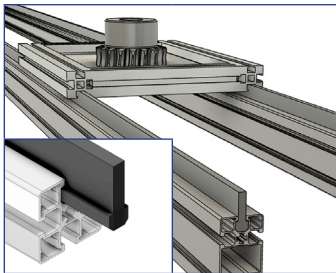

- Flexible Alignments
- Lateral Conveyor Side Guides
- Guidance Device for Sliding Doors, and Other Sliding Elements

### Rail W/ Wheel Bearing

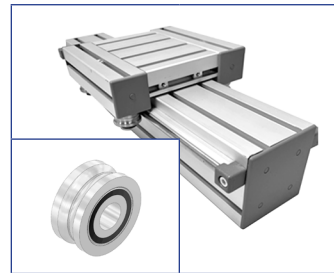

- High Precision
- Handles Heavy Loads - Automated or Manual Adjustment Applications
- Pick and Place
- Robotic Palletizer
- Measuring System

### UHMW W/ Wheel Bearing

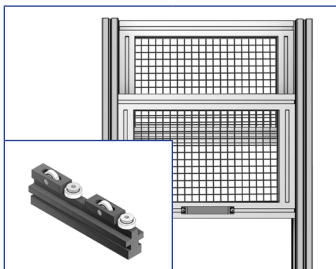

- Perfect for Small Vertical Windows and Doors
- Small / Light Loads
- Flexible Alignment

### Profile Rail Linear Guides

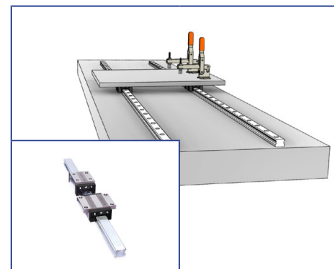

- Cost-Effective, Transparent-Grade Profile Rail Solution for Cost-Effective Applications
- Double-Faced Ball Track Bearing Arrangements Provide Compliance During Installation as Well as Equal Load-Carrying Capacity